



STAAD.Pro® V8i

A Leading Choice in Structural Analysis and Design Software

STAAD.Pro V8i is a comprehensive and integrated finite element analysis and design offering, including a state-of-the-art user interface, visualization tools, and international design codes. It is capable of analyzing any structure exposed to static loading, a dynamic response, wind, earthquake, and moving loads. STAAD.Pro V8i provides FEM analysis and design for any type of project including towers, culverts, plants, bridges, stadiums, and marine structures.

Advanced Analysis and Design

With an array of advanced analysis capabilities including linear static, response spectra, time history, cable, imperfection, pushover, and non-linear analyses, STAAD.Pro V8i provides your engineering team with a scalable solution that will meet the demands of your project every time.

STAAD.Pro V8i reduces the man-hours required to properly load your structure by automating the forces caused by wind, earthquakes, snow, or vehicles. No matter what material you are using or what country you are designing your structure for, STAAD.Pro V8i can easily accommodate your design and loading requirements, including U.S., European (including the Eurocodes), Nordic, Indian, and Asian codes. Even special codes like AASHTO, ASCE 52, IBC, and the U.S. aluminum code are accommodated.

With an unparalleled quality-assurance program, open architecture for customization, and a 25-year track record – including such projects as the MCI Stadium in Washington, D.C., Wimbledon Court No.1 in London, and the tallest transmission tower in Asia – STAAD.Pro V8i is the perfect workhorse for your design firm.

STAAD.Pro V8i will eliminate the countless man-hours required to properly load your structure by automating the forces caused by wind, earthquakes, snow, or vehicles.

Extremely Flexible Modeling Environment

The power of STAAD.Pro V8i is in an interface that is based on the latest programming technology, which means that 80 percent of new users learn to use STAAD.Pro V8i efficiently in under two hours. Along with our tutorial movies,

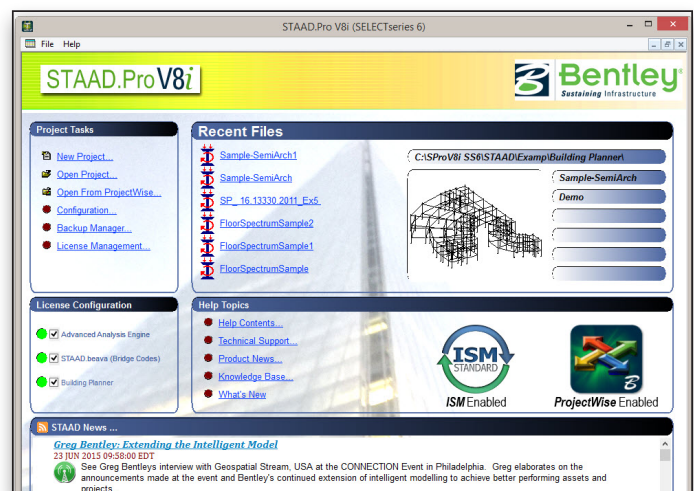

Clear Start Page and new structure wizard allows user configuration and easy access into the program.

we include online help and dozens of examples to illustrate solutions to commonly raised modeling, analysis, and design issues.

Broad Spectra of Design Codes

Steel, concrete, timber, and aluminum design codes from all around the world including a number of historical codes means that you can take STAAD.Pro V8i to wherever your company works.



Interoperability and Open Architecture

STAAD.Pro V8i is more than an analysis and design tool. From simple importing of CAD models to creating custom links and developing third-party applications using OpenSTAAD, it can be the heart of your structural solution. When integrated with ProjectWise® V8i, your STAAD.Pro V8i models can be efficiently managed with the leading project collaboration system. By using the ISM integration, models become part of an integrated workflow.

Quality Assurance

STAAD.Pro V8i undergoes the most demanding quality and testing regime. Our procedures follow the requirements of 10CFR Part 50, 10CFR21, and ASME NQA-1-2000 verifying that STAAD.Pro has been approved for use on the design of nuclear installations.

System Requirements

Processor:

Intel® Pentium or AMD processor 2.0 GHz or greater

Operating system:

Windows 7 or Windows 8

System memory:

Minimum of 512 MB of RAM, 2 GB recommended.

Disk space:

Requirements will vary depending on the modules you are installing. A typical minimum is 500 MB free space.

Display: Graphics card and monitor with 1280x1024 resolution, 256 color display (16-bit high color recommended)

A sound card and speakers are needed for the tutorial movies and slide shows.

Find out about Bentley at: www.bentley.com

Contact Bentley

1-800-BENTLEY (1-800-236-8539)
Outside the US +1 610-458-5000

Global Office Listings

www.bentley.com/contact

STAAD.Pro V8i At-A-Glance

User Interface

- Graphical tools. Models can be created quickly and accurately using structural grids, tooltips to highlight data, frame generators, and a structure wizard for standard structural frames
- Visualization. From simple wire frames for speed, accuracy, and ease of use to fully rendered 3D models for clear mass distribution and presentation
- All new advanced IDE style Editor with IntelliSense, Database Integration, and context sensitive help
- Meshing tools. Triangular or quadrilateral meshes created from zones within defined models or imported from DXF files
- Load generators. Seismic UBC, IBC, ASME wind and snow, bridge loading BEAVA
- Customizable interface with VBA tools. Create windows and tables to your own specifications. SQL query builder

Objects

- Beams. Standard linear, curved and physical beams, compression/tension only, with databases of sections from around the world
- Plates. 3- or 4-noded 2D plates and surface objects with holes
- Solid. Solid 3D bricks from 4- to 8-noded
- Supports. Foundation and multi-linear springs
- Loads. Full range of loads for static and dynamic analysis that can be defined explicitly or calculated using the wide range of load generators

Analysis

- Elastic. Traditional first-order including iterative one-way analysis
- P-Delta. Both large and small P-Delta including stress-stiffening effects
- Cable. Account for the changing stiffness of cables due to loading
- Imperfection. Account for imperfections in structural geometry
- Dynamic. Modal analysis including stress-stiffening eigensolution and steady-state options, time history, and response spectrums
- Buckling. Identify the eigen buckling factor
- Basic and advanced solvers. The standard solver, the staple of STAAD® for over 20 years is now complemented by an advanced solver that can be up to 1,000 times faster
- Pushover. A solution to the requirements outlined in FEMA 356:2000
- Code checking and design
- Steel Design. Choose from 50 codes from around the world

- Concrete Design. Select from 40 design codes, either in batch processing or the interactive Concrete Design Mode
- Timber. Support four design codes.
- Aluminum design
- Shear wall designs for U.S., Indian, and British codes

Post Processing

- The STAAD.Pro V8i interface is configured to suit the model to ease access to the required data
- Interactive graphics. Linked tables and windows to get direct feedback from one item in related windows
- Output file. Simple clear information to verify the analysis
- User report. Create high-quality documents
- Contoured stress plots. Using automatic or user-configured scales, colors, and limits
- Animations. View displacements, stress contours, or mode shapes dynamically

Interoperability

- RAM™ Connection V8i. Joints defined in the model with the forces calculated from the analysis can be passed into the leading connection design application
- Bentley AutoPIPE® V8i. Pass the STAAD.Pro V8i structural steelframe into AutoPIPE V8i to correctly account for the pipe support stiffnesses and import the pipe engineers support reactions back into the model for an accurate design in a fraction of the time of traditional methods
- STAAD.foundation V8i and STAAD Foundation Advanced V8i. Import the STAAD.Pro V8i support reactions and positions directly to design the structure foundations
- RAM™ Concept V8i. Floor slabs can be identified and linked to RAM Concept for full RC and PT design and detailing in a state-of-the-art application
- ProStructures and AECOSim Building Designer. Two-way link to support creating models with design and construction documents.
- Full concrete design and detail with RC DC directly from the Building Planner Mode
- OpenSTAAD. A complete set of functions that make OpenSTAAD an API from which data can be extracted directly into applications such as Microsoft Word or Excel, or your own application. Use STAAD.Pro V8i to create models, run the analysis, and view the result with your own interface
- CAD, DXF. Use CAD models as the base wire frame, structural grid or outline of a complex deck that needs to be meshed
- CIS/2. Exchange data with other steel design packages
- Section Wizard. Calculate properties of built-up sections, drawn freehand, parametrically defined, or imported from a CAD drawing

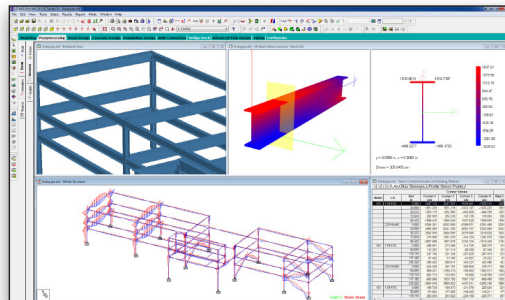

Interactively view stresses on a profile at any cross section on a selected member and load case.

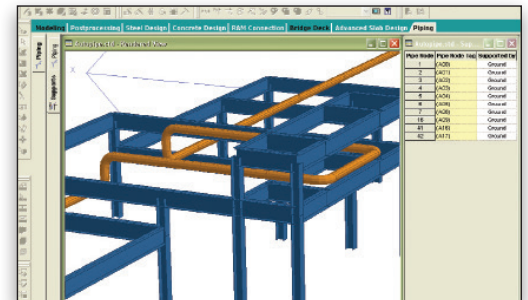

Pipe work designed in AutoPIPE V8i can be imported and graphically linked to the structure to import the loading.